

Mechanical Integration

The light is equipped with 4 combined mounting positions of M5 threaded holes and M4 through holes. It can be used to fix the lighting to the specified position. To secure a long lifetime additional heat transfer measurements at the holding positions are highly recommended.

Example: Model SRL-10

More 2D and 3D drawings can be found online:
www.mbj-imaging.com

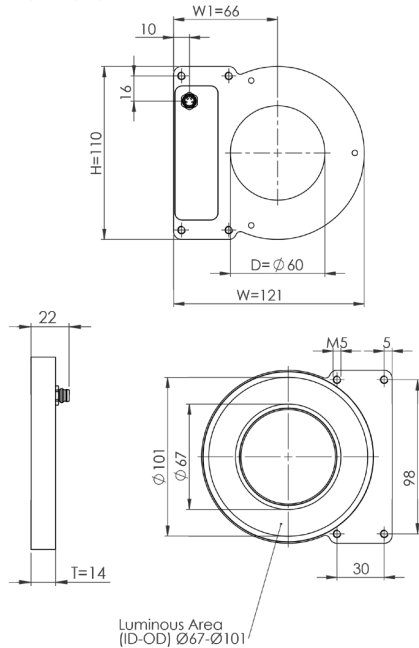

Specification	Ringlight Series
Operating temperature	10°C to 30°C / 45°C ¹⁾
Certifications	CE, RoHS
Degree of protection	IP54 or IP67 ²⁾
Humidity	30% to 70%

- 1) Max. of 30°C is recommended for steady light operation w/o additional heat transfer measurements, for max. 45°C a thermal connection is mandatory. Max. of 45°C is also permissible for flash light operation with a max. 10% duty cycle.
2) MBJ LED lights are protected against the ingress of solids and water in accordance with the selected protection class and applicable standards. Permanent protection against liquids containing solvents, such as cleaning agents, machine emulsions or other lubricants, cannot be guaranteed. IP is only valid with a connected cable (MBJ cable recommended).

Safety Notes

Before working with this unit, read the warning and application instructions carefully and completely before operating the device.



1. The device is designed for indoor use only.
2. **Light** – Due to the risk of flash burn of the eyes it is not recommended to look directly into the light source. The lighting must be switched off before installation and/or maintenance. The device must not be used when a failure may cause a personal injury.
3. **Heat** – In case of insufficient heat dissipation or when running the light in flash mode with a too high duty cycle, the surface temperature may exceed 60 °C. Keep off flammable materials at any time.
4. **Electricity** – The housing is electrically isolated from the ground of the power supply. Exceeding the permissible input voltage U_{in} or $U_{LED(+)}$ can lead to the destruction of the device or to a significant shortening of the lifetime of the LEDs in the device.
5. **Usage** – Please prevent mechanical stress to the light surface during operation. This will lead to an inhomogenous light emission.
6. **Cleaning** – The light emission surface has to be cleaned with a standard glass cleaner and a soft cleaning cloth. Do not use other material for cleaning as it will damage the device.

03202.05 Manual MBJ Ringlight SRL-Series, August 2023

MBJ Imaging GmbH

Jochim-Klindt-Straße 7 +49 4102 778 90 - 31
22926 Ahrensburg, Germany sales@mbj-imaging.com
www.mbj-imaging.com



Operating Manual Technical Data

Ringlight Series



Model Sizes in Series

The light is available in the following sizes ¹⁾

SRL-04	SRL-07	SRL-10	SRL-12
--------	--------	--------	--------

1) Size definition: SRL-07 refers to an outer luminous area of 70 mm.

Possible LED Colors

LED	Abbr. ¹⁾	Peak Wavelength ²⁾
White	-WT	5000 K, CRI80
Red	-RD	near 625 nm
Infrared	-IR	near 850 nm
Green	-GN	near 525 nm
Blue	-BE	near 465 nm
Yellow	-YE	near 580 nm

- 1) Color option will be added to the model name after the size information. Ringlight SRL-07-IR refers to a ringlight with 850 nm infrared light.
2) This is an approximated value. The exact value also depends on LED temperature and LED current.

Electrical Connection

The lighting is equipped with an 4 pin M8x1 connector.

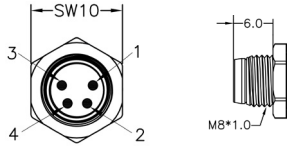

Pin	Color ¹⁾	Standard (-s)	Direct (-x) ²⁾
1	brown	24 VDC	LED (+)
2	white	Dim	LED (+)
3	blue	Trigger	LED (-)
4	black	Ground	LED (-)

1) wire color of MBJ lighting cable

2) connection to 24VDC without external LED controller may destroy the unit

Additional Information:

Pin 3 (Trigger) is an 'active high' input signal with 5...24V=ON and 0...1V=OFF, it is a high resistance current sink with 0.2 mA for 5V and 5 mA for 24V

Pin 2 (DIM) is used as brightness control and operation mode switch, it is a high resistance current sink with 0.2 mA for 5V and 1 mA for 24V.

For the connection it is recommended to use the MBJ lighting cable with a maximum length of 10 m.

SRL-04: due to the small size of this ring light the -s controller is integrated into the cable (cable controller).

Integrated Controller (-s)

Supported operation modes with the integrated LED controller

Pin 2 (Dim)	Operation mode
24V	steady light ¹⁾
1...10V	steady light with brightness control ²⁾
24V	triggered light
GND	triggered flash light with max. 20 ms and up to 100% more light intensity ³⁾

1) Pin 3 (Trigger) needs permanent 24V to activate steady light mode.

2) PWM with 3.8kHz clock is used, recommended minimal camera exposure is 5ms.

3) Latency between trigger and LED light ON is about max. 30 μs, the maximum recommended clock speed is 1 kHz, the maximum recommended duty cycle is 25% and the minimum recommended flash time is 100 μs.

Application Samples for (-s) controller

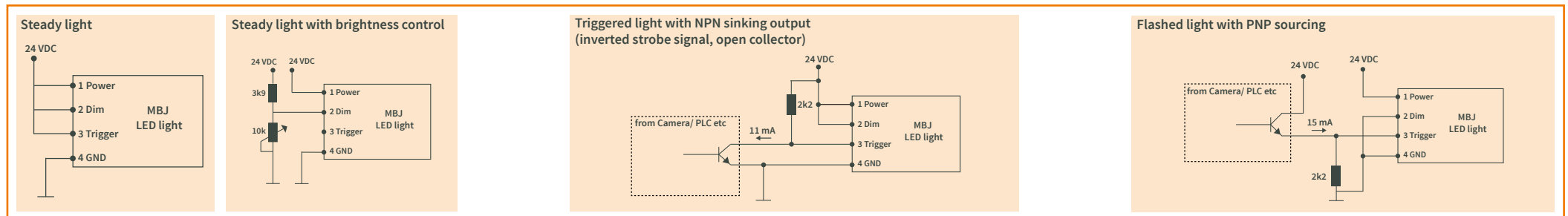

Specification	SRL-04 / SRL-04-IP	SRL-07 / SRL-07-IP	SRL-10 / SRL-010-IP	SRL-12 / SRL-12-IP
Optical parameter				
Luminous area (ID-OD)	36 mm - 52 mm	53 mm - 72 mm	67 mm-101 mm	87 mm - 121mm
Light emission	Ring shaped light field with direct fired LED, slightly diffuse emission			
Recommended use	Commonly used as incident light for brightfield application, placed around the MV camera, e.g. for OCR or print inspection			
Electrical parameter				
Available interfaces	-s with integrated LED Controller and 4 operation modes; -x with direct LED access (external LED control is required)			
Uin for -s Version	24 VDC +/- 5%			
U _{LED(+)} range for -x version ²⁾	WT / BE / YE: 17 ... 20 VDC; GN: 20 ... 23 VDC; RD: 12 ... 15 VDC; IR: 9 ... 12 VDC			
Typical Power (-s version)				
Steady light operation (white / red / IR) ³⁾	3W / 2W / 3W	6W / 5W / 5W	9W / 7W / 7W	11W / 9W / 9W
During ON time at flashed light operation ⁴⁾	8W	15W	23W	25W
Recommended LED current (-x version)				
Steady light (100% duty cycle)	150 mA (225 mA for IR)	300 mA (450 mA for IR)	450 mA (600 mA for IR)	600 mA (900 mA for IR)
Flash light (50% duty cycle, <500 ms pulse)	300 mA (225 mA for IR)	600 mA (450 mA for IR)	900 mA (600 mA for IR)	1200 mA (900 mA for IR)
Flash light (25% duty cycle, <50 ms pulse)	450 mA (225 mA for IR)	900 mA (450 mA for IR)	1350 mA (600 mA for IR)	1800 mA (900 mA for IR)
Flash light (10% duty cycle, <5 ms pulse)	600 mA (450 mA for IR)	1200 mA (900 mA for IR)	1800 mA (1200 mA for IR)	2400 mA (1800 mA for IR)
General parameter				
Dimension (H x W x D)	60 mm x 60 mm x 12 mm	80 mm x 92 mm x 12 mm	110 mm x 121 mm x 14 mm	130 mm x 141 mm x 14mm
Lens hole diameter [ø]	34 mm	45 mm	60 mm	80 mm
Weight	60 g ⁵⁾	120 g	205 g	300 g
Material	Anodized aluminum housing with PMMA light cover			
Connector	M8x1 socket, 4 pin, male (for pinning details refer to chart "Electrical Connection")			
Recommended light working distance	50 mm-150 mm	75 mm-200 mm	100 mm-250 mm	150 mm-300 mm
Accessories	For cable, mounts and LED controller please check www.mbj-imaging.com			

1) Values are approximate with a +/- 7% tolerance.

2) Lower voltage value refers to steady light, higher voltage value refers to flash light, please see max. allowed current in the rows below.

3) Power for Yellow/Blue is comparable to White, Power for Green is approx. 1,2 times higher than White.

4) Triggered flash light with max. 20 ms and up to 100% more light intensity, calculated for White.

5) Without cable controller.