

Lt16059H

High Performance 16 Megapixel 35 mm CCD USB 3.0 Camera. Ideal for Traffic, UAV, and Industrial Inspection



High Resolution CCD Sensor with Global Shutter

Lumenera's progressive scan Lt16059H 16 MP digital camera is built for rugged 24/7 use. The 'H' stands for "higher performance" via the use of the OnSemi KAI-16070 35 mm format CCD sensor. The KAI-16070 sensor with quad-tap output provides high smear rejection (-115 dB) and high dynamic range. This sensor supports a global electronic shutter that captures high quality, high-speed images with zero blur. A fully integrated Canon EF lens controller offers flexibility via remote control (no external cabling is required). The industrial-grade Lt16059H is ideally suited for applications requiring high sensitivity and high resolution such as: traffic, automated license plate recognition (LPR), UAVs, and industrial inspection.

High Quality Images for Difficult Lighting Environments

The Lt16059H is designed for applications requiring higher sensitivity via the larger 7.4 x 7.4 µm pixels of the KAI-16070 sensor. For very challenging lower light applications, an optional Truesense Sparse color sensor is available to provide double the improvement in light sensitivity compared to a standard color Bayer part. Full streaming uncompressed video and still image captures are easily controlled through a set of stable and reliable USB 3.0 device drivers. Region of interest and binning modes allow the camera to run at faster frame rates while only providing the image data you need. Image capture synchronization is achievable using either a hardware or software trigger.

Built for Reliability and Ease of Integration

The robust enclosure of the Lt16059H is designed to effectively dissipate heat and increase reliability when coupled with a heat sink. The fully locking USB 3.0 cabling, power connector and digital interface ensure a simple plug-and-play installation. No framegrabber is required. Simplified I/O cabling is provided through a locking GPIO connector supporting 1 optically isolated input, 1 optically isolated output and 2 software configurable, bi-directional IOs.

Maximize Camera Performance Within Your Own Application

The Lumenera Camera SDK provides a full suite of features and functions that allow you to maximize the camera's performance within your own vision application. The SDK is compatible with all of our USB and GigE-based cameras and includes over 50 sample applications. Microsoft DirectX/DirectShow, Windows API, .NET API, and Linux API interfaces are provided, allowing you the choice of application development environments from C/C++ to VB.NET or C#.NET. Full inline IntelliSense autocompletion is provided with the .NET API interface and is accompanied by a full API manual describing all camera functions and properties.

Superior Technical Assistance Center

All Lumenera cameras are supported by an experienced team of imaging experts for pre-sale and post sale technical support. We understand your imaging needs and are here to help you get the most out of your camera.

Features

- Canon EF lens* mount with fully integrated controller for auto focus/iris supported by our API, increases accuracy and flexibility for remote applications
- High quality Truesense KAI-16070 CCD sensor provides excellent dynamic range, low smear and excellent color reproduction
- Fanless body, small footprint and lower power requirements
- Color or monochrome, interline transfer, progressive scan 16 MP CCD sensor
- USB3 Vision Compliant
- Locking industrial USB 3.0 interface
- Hirose GPIO connector with power input, 1 optically isolated input, 1 optically isolated output and 2 software configurable, bi-directional IOs, for control of peripherals and synchronization of lighting
- 256 MB RAM frame buffer
- Simplified cabling - video, and full camera control over a single USB cable
- 8 mounting points and 2 tripod (1/4"-20) mounts
- Binning improves sensitivity and Region of Interest (ROI) provides higher frame rates
- FCC Class B, CE Certified
- Select 8 or 14-bit pixel data
- DirectX/DirectShow compatible
- Software compatible with Windows 10, Windows 8.1, Windows 7, Linux, 32 and 64-bit operating systems
- Complete Windows and Linux SDKs available
- Industry-leading four (4) year warranty

* Compatible with most EF lenses. Not all EF lenses supported.



Quantum Efficiency Curves (Color)

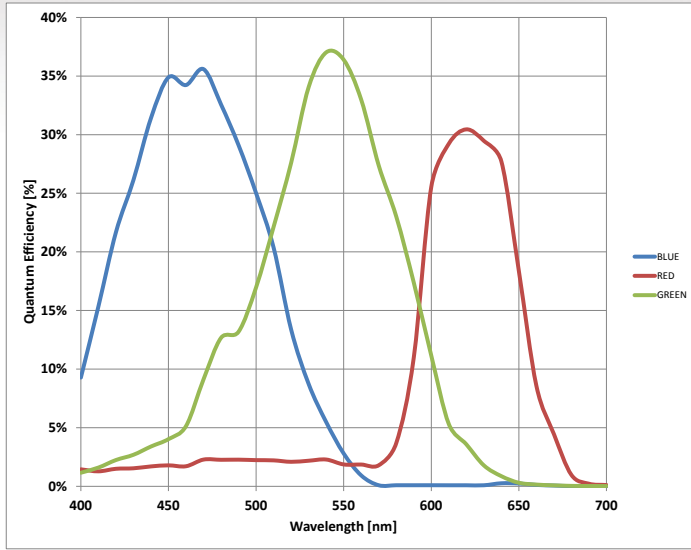

Quantum Efficiency Curve (Monochrome)

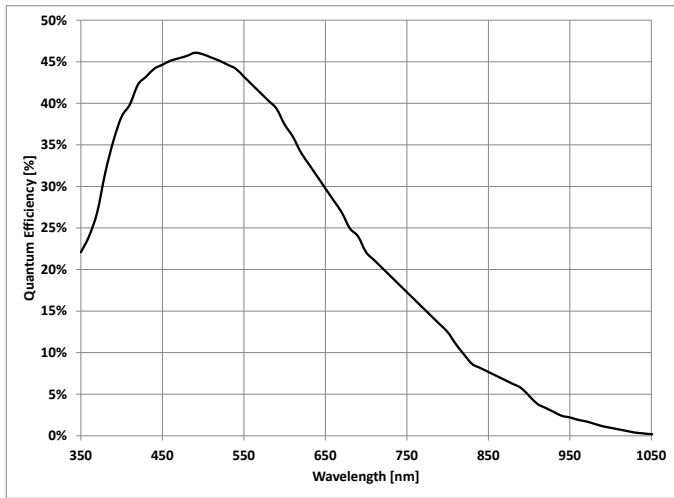

Ordering Options	
Lt16059HC	15.7 MP Color Camera, La21224L 12 VDC Power supply
Lt16059HM	15.7 MP Monochrome Camera, La21224L 12 VDC Power supply
LuSDK	Software Developer's Kit (Web Download)
La3000PAFL	GPIO 12-pin connector cable (36") with leads

Sensor Specifications	
Image Sensor	OnSemi KAI-16070, CCD, color, monochrome
Optical Format	35 mm (43.2 mm diagonal)
Imager Size	Diagonal 43.20 mm
Pixel Size	7.4 x 7.4 µm
Resolution	4864 x 3232 pixels
Region of Interest Control	Any multiple of 16x16 pixels, 16x16 pixel minimum
Camera Specifications	
Frame Rate	12 fps at full resolution in overclocked mode, faster with ROI
Bit Depth	8 or 14-bit
Binning	2x2, 4x4, 8x8
Electronic Shutter	Global
Exposure Control	Manual and automatic control
Exposure Range	Video mode: ~50 µs to 750 ms (4-tap) / 850 ms (2-tap) / 1050 ms (1-tap) (video) Snapshot mode: ~50 µs to 71 minutes
Gain Control	Manual and automatic control
Gain Range	0.6 to 46x
White Balance	Manual and automatic control
Trigger Modes	Hardware and software triggerable
Camera Characteristics	
Sensitivity	4.7 DN/(nJ/cm ²) (mono), 3.7 DN/(nJ/cm ²) (color)
Dynamic Range	66.7dB
Full Well Capacity	~33,700 e-
Quantum Efficiency	46% (mono-peak), 37% (color-peak @ 540nm)
Read Noise	15.5 e- (Quad Tap, Slowest Clock, 20 °C ambient)
Dark Current Noise	5.8 e-/s/pixel (at 50 °C camera temp)
Mechanical Specifications	
Data Interface	USB 3.0, locking connector
General Purpose I/O	Locking Hirose HR10A-10R-12PB(71)
Lens Mount	Canon EF mount (focus/iris support) for most EF lenses. Supports other mounts with 3rd party adapter rings (no focus/iris support).
Dimensions	76.2 x 76.2 x 82.6 mm (3.0 x 3.0 x 3.25 inches)
Mass	600 g
Operating Temperature	0 to 50 °C - Requires recommended heat sinking to external enclosure
Storage Temperature	-30 to 70 °C
Operating Humidity	5 to 95 %, non-condensing
Shock / Vibration	50 g shock, 5 g (2 to 200 Hz) vibration
Onboard Memory	Camera has onboard non-volatile memory storage
Camera Software	
Operating Systems	Windows 10, Windows 8.1, Windows 7, Linux, 32 and 64-bit operating systems
Software Interfaces	Windows API, .NET, DirectX /DirectShow, Linux API, USB3 Vision
Power and Emissions	
Power Consumption	7.2 W (single tap, slowest clock), 13.3 W (quad tap, fastest clock)
Power Requirement	12 V DC via DC connector or GPIO. La21224L locking power supply included.
Emissions Compliances	FCC Class B, CE Certified
Hazardous Materials	RoHS, WEEE Compliant
Warranty	Four (4) year
Customization Options	
-SCI	Scientific grade
-WOIR	AR/AR glass within lens mount
-WOG	Without any glass within lens mount
-WOCG	Without sensor cover glass
-TSFP	Truesense Sparse Filter Pattern sensor



Mechanical Drawings

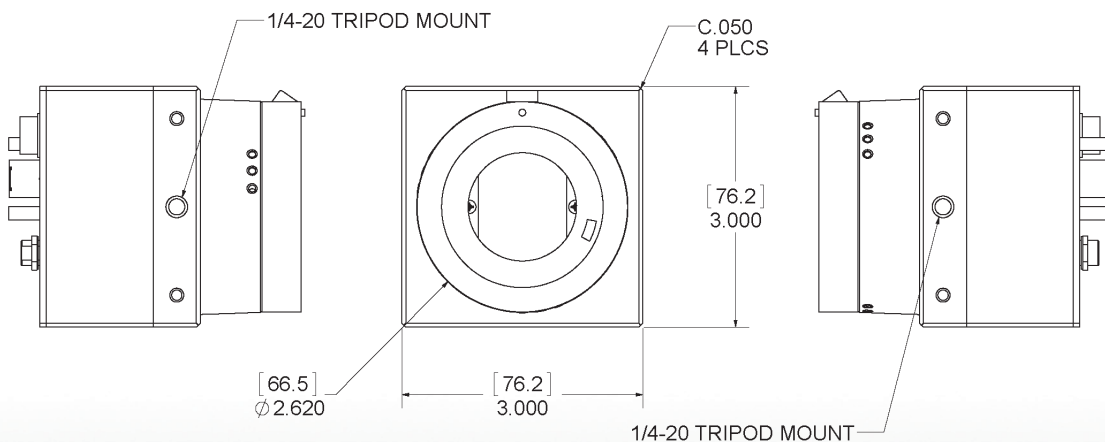
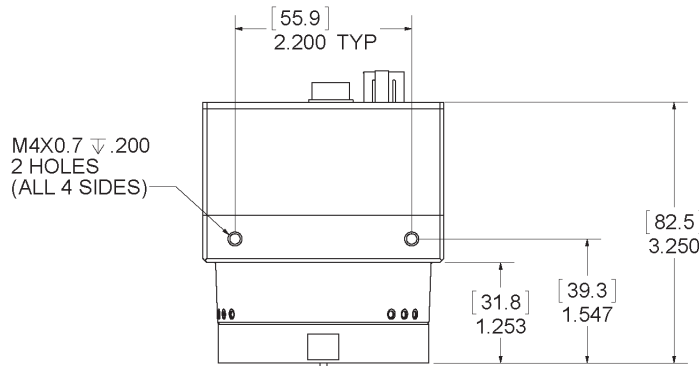
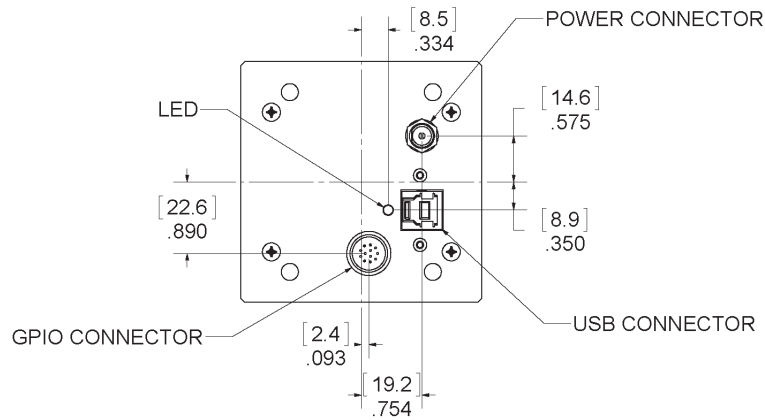
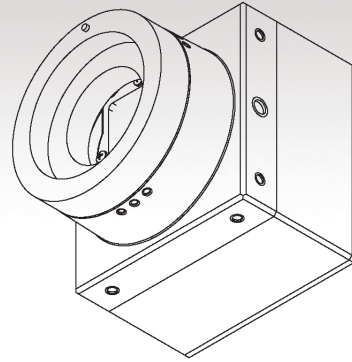

Measurements = [mm]
inches

