

TERA15-FC

Fiber Coupled THz Antennas for 1560 nm

MenloSystems

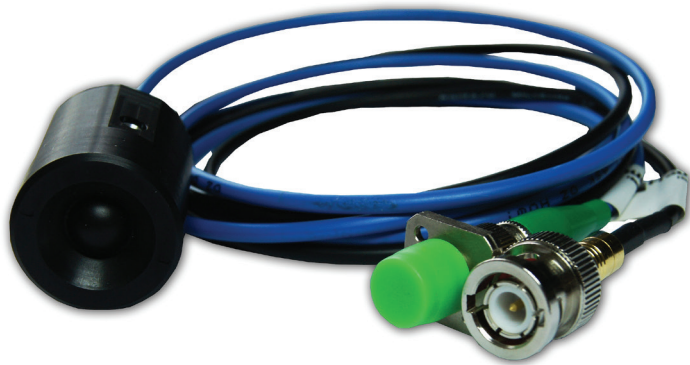

Our fiber coupled TERA15-FC antenna modules for 1560 nm laser wavelength are the unique solution for flexible and robust all-fiber THz-TDS systems. The high-power antenna technology is based on InGaAs/InAlAs multilayered mesa structures with high voltage biasing of the emitter. For highest THz bandwidth we provide optimized structures for emitter and detector. The polarization maintaining (PM) coupling fiber ensures reliable and stable operation even under harsh environmental conditions.

KEY SPECIFICATIONS

- >4.5 THz Bandwidth
- >80 dB Dynamic Range
- PM Fiber Coupling

APPLICATIONS

- THz Generation & THz Physics
- THz Imaging

FEATURES

- Optimized for Lasers Around 1560 nm and Pulse Width <100 fs at 100 MHz Repetition Rate
- Higher Bias Voltage with Unipolar Modulation
- Specific Antenna Design for Emitter / Receiver Applications
- Flexible Fiber Coupled Modules
- Two Perpendicular Mounting Possibilities (M4 Thread)

RECOMMENDED OPTICAL LIGHT SOURCES

- T-Light
- C-Fiber

PERFORMANCE DATA

Test Conditions for Data Plots

Laser model: Menlo Systems C-Fiber, 1560 nm center wavelength, 100 MHz repetition rate, dispersion pre-compensated for pulse width <100 fs at fiber coupled antenna.

Averaging time: 1000 s

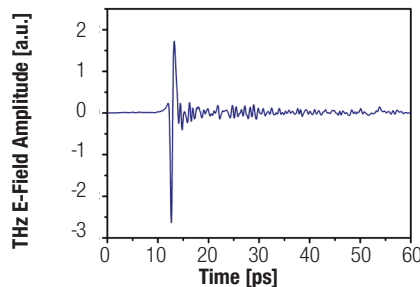

Emitter TX:

Average optical power: 20 mW

Electrical input: 100 V

Receiver RX:

Average optical power: 16 mW

Electrical in-/output: 10^7 , amplification using transimpedance amplifier

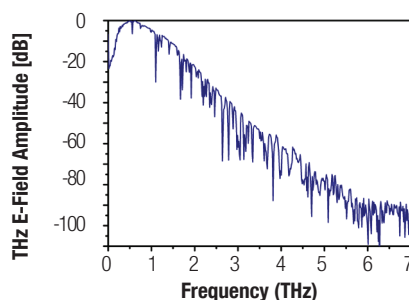

ANTENNA

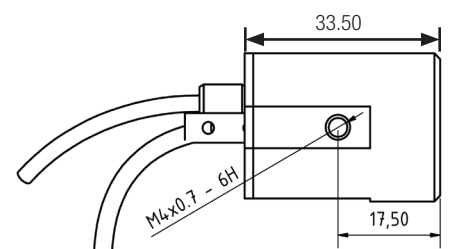
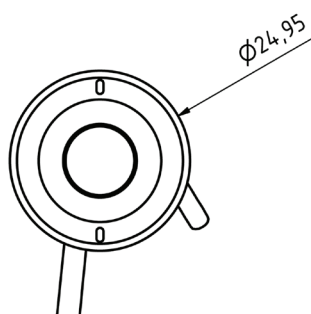
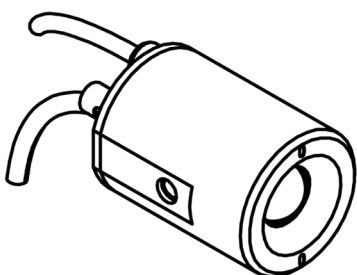

TERA15-FC



Fiber Coupled THz Antennas for 1560 nm

SPECIFICATIONS	TERA15-TX-FC EMITTER	TERA15-RX-FC RECEIVER
Photoconductive Material	InGaAs/InAlAs	LT InGaAs/InAlAs
Spectral Photosensitivity	up to 1.57 μm	up to 1.57 μm
Antenna Type	strip line: 100 μm	dipole: 25 μm ; gap: 10 μm
THz Beam Divergence	$\pm 12.5^\circ$ FWHM (measured with Golay cell)	$\pm 12.5^\circ$ FWHM (measured with Golay cell)
THz Power	up to 60 μW (measured with calibrated pyrodetector)	n.a.
Electrical Connection	1 m connector cable, LEMO 0S	1 m SMB connector cable, BNC adapter
Fiber Patch Cord	l = 100 cm, FC/APC connector, PM-PANDA fiber; SMF28 fiber on request	l = 100 cm, FC/APC connector, PM-PANDA fiber; SMF28 fiber on request

OPERATION CONDITIONS

Average Optical Power	<30 mW	<40 mW
Optical Pulse Duration	<100 fs	<100 fs
Repetition Rate	100 MHz (80...250 MHz)	100 MHz (80...250 MHz)
Bias Voltage	100 V (unipolar), 0 - 100 V modulation	n.a.
Modulation Frequency	up to 75 kHz (unipolar)	n.a.

CHARACTERISTICS MEASURED IN FIBER TESTBED

THz Pulse Shape	Peak-to-peak time difference <800 fs
Maximum of Fourier Spectrum	>0.3 THz
20 dB Level	>1.5 THz
Noise Floor	>4.5 THz

Please refer to the recommended laser parameters and bias voltage. Improper use or experimental conditions are excluded from warranty.

Caution: Maximum optical power 30 mW at emitter, 40 mW at receiver at 100 MHz laser repetition rate.

ORDERING INFORMATION

Product Code	TERA15-TX-FC	TERA15-RX-FC
--------------	--------------	--------------

Please call for pricing. Specifications are subject to change without notice. Custom modifications are available, please inquire.

